

ITEM NO.	DESCRIPTION	QTY.
1	4 AWG, 8 INDEX DIE SET	1

CATALOG NUMBER	DESCRIPTION
HU4CRT	4 AWG, 8 INDEX DIE SET

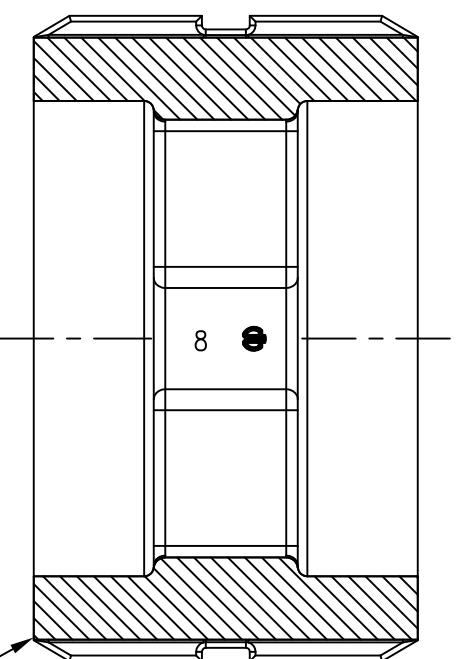
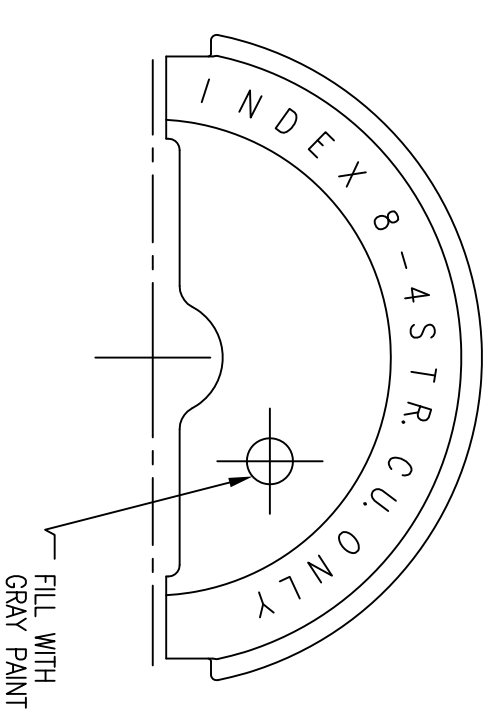
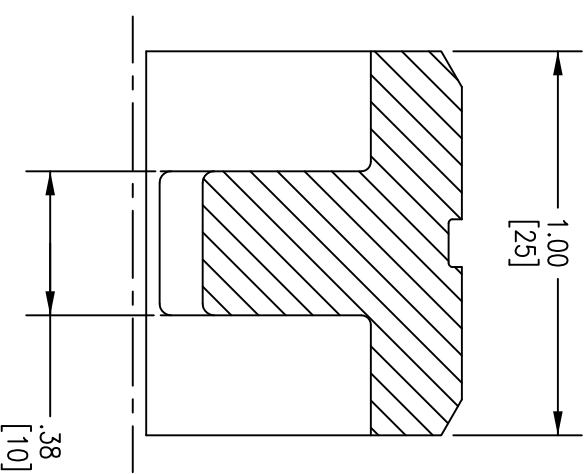
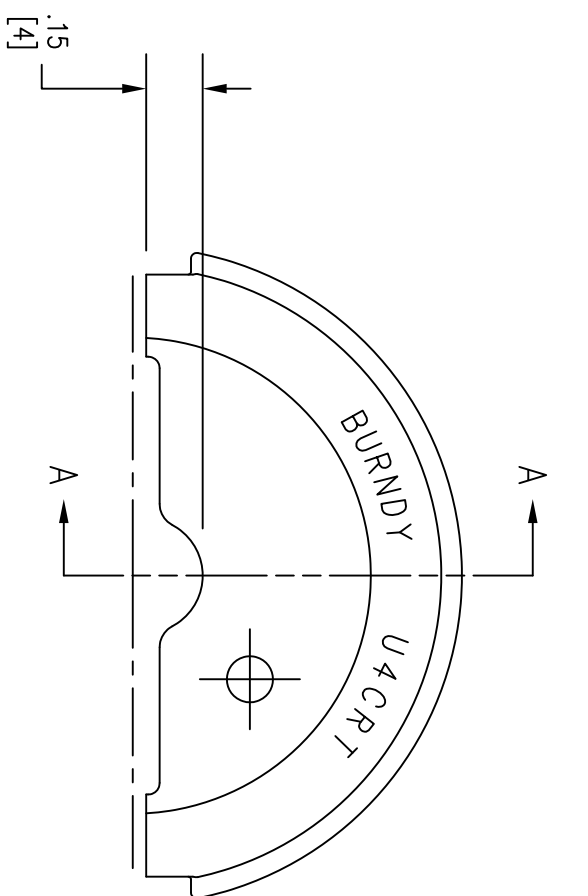

- NOTES:
- DIMENSIONS IN BRACKETS [] ARE IN MILLIMETERS ROUNDED OFF TO THE NEAREST MILLIMETER, UNLESS OTHERWISE SPECIFIED, AND ARE FOR REFERENCE ONLY.
 - 4/0 STR. & SMALLER, THE SAME DIES WILL CRIMP CLASS "B" THRU "M" STRANDING.
 - MATERIAL: STAINLESS STEEL.
 - FITS HPAT750U AND HY750CHSXT COMPRESSION TOOLS.
 - SPECIFICATIONS SUBJECT TO CHANGE WITHOUT NOTICE.

REV.	ECN	DATE	DESCRIPTION	CHG BY	APPD BY
1	17987	8/13/12	INITIAL RELEASE	CG	

Created on AUTOCAD

DIMENSIONING AND TOLERANCE PER
ANSI Y14.5M-1982
UNLESS OTHERWISE SPECIFIED,
DIMENSIONS ARE IN INCHES (MM).
TOLERANCES
.XX = ±.01 (.25)
.XXX = ±.005 (.127)
.XXXX = ±.0025 (.0635)
ANGLE TOL ±1°

PROJECT REFERENCE:
2011-041

MATERIAL:
SEE NOTES

DRAWN BY:
C. GRIBBLE 8/13/12

CHECKED BY:

APPROVED BY:

HUBBELL
Hubbell Premise Wiring
HUBBELL INCORPORATED (Delaware)
23 CLARA DRIVE, SUITE 103 MYSTIC, CT 06355

TITLE:
DIE SET, 4 AWG, 8 INDEX
U DIE SET FAMILY

SIZE: **C** DRAWING NO. **HW514110C** REV. **1**

SCALE: 1/1 SHEET 1 OF 1